



PAT McCRORY
Governor

NICHOLAS J. TENNYSON
Secretary

October 12, 2016

NOTICE TO PROSPECTIVE BIDDERS

Contract Number: 11647857
WBS Number: "TBD" (To Be Determined)
County: Lee
Description: Long arm mowing with mulching/pickup as needed

Subject: Addendum #1

The following revisions have been made to the project proposal associated with the above referenced project:

- The provision for *LONG-ARM MOWING WITH MULCHING/PICKUP* has been revised. Please replace the original provision with the attached revised provision.

This addendum letter and attached special provision shall be attached to the front of the contract proposal. This Addendum will also be available for download on the Division 8 Letting Page at: https://connect.ncdot.gov/letting/Pages/Letting-List.aspx?let_type=8

We apologize for any inconvenience this may have caused. If this office can provide additional information, please call me at (910) 944-2344.

Sincerely,

DocuSigned by:
Jeffrey A. Stroder
A3C912A7820D436...

Jeffrey A. Stroder, PE
Division Proposal Engineer

cc: Mark Thompson
James Garner
File

LONG-ARM MOWING WITH MULCHING/PICKUP

The Contractor shall furnish to the Department of Transportation the fully operated equipment described in this contract as needed for vegetation trimming using long arm mowers with mulching/pickup along designated routes within the county.

The Contractor shall furnish equipment in good operating condition and operated by properly trained and qualified personnel. The personnel operating the equipment shall be employees of the Contractor or approved Subcontractor and the Contractor shall be responsible for all operators during the performance of the contract. The personnel shall be subject to the directions of the Department of Transportation. The Department of Transportation may refuse delivery or may reject any equipment found to be defective and/or inadequately operated.

The County Maintenance Engineer will select and coordinate the locations to be mowed and provide a map of mowing routes to the contractor. All work must be accomplished during daylight hours. No night work is permitted.

Units of the Bid Sheets are for bid evaluation only and do not reflect purchase order limits. Purchase order quantities will be based on actual need. Section 104-5 of the Standard Specifications will not be applicable. The Engineer reserves the right to make, at any time during the work, such changes in quantities as necessary to satisfactorily complete the project.

The scope of work is as follows:

Two (2) long arm mowers with traffic control for 2 lane two way traffic control in accordance with the MUTCD. Please note that some 2 lane facilities may have short turn lanes at intersecting roads. Payment for this work will be made under the item "Two (2) Fully Operated Long arm Mowing Tractors with Traffic Control"

All routes shall be mowed to the top of the cut slope, to the bottom of the fill slope, or to the limit of the equipment. Vegetation hanging over the cut slope shall be mown to the limit of the mower. All vegetation **five inches (5") in diameter or less** shall be cut. Cut vegetation shall be cleaned up or mulched. All brush or debris which falls into the roadway shall be immediately removed by the Contractor. See diagrams below.

Equipment

The Contractor shall provide the following types of equipment:

All long arm mowers provided under this agreement shall be hydraulic powered and shall reach a minimum of twenty feet (20 ft) from the center of the tractor. Mower hydraulics shall be controlled from within the driver/passenger compartment. The tractor shall have sufficient horsepower to operate the mower per mower manufacturer recommendations and shall be capable of cutting up to a 5" diameter tree or tree limb. The Department will not be responsible for damage to the Contractors' equipment.

Mowers are to be equipped with shields, which preclude foreign objects from being thrown out from the cutting unit enclosures. Tractors shall be equipped so as to conform to the prevailing

Occupational Safety Health Act Standards. All tractors provided by the Contractor shall be equipped with warning lights visible from 360 degrees with at least half of the lights being amber in color, with at least one top of cab mounted rotating amber light. All equipment shall also be equipped with reverse gear warning devices. The Contractor must furnish, mount, and maintain a "Caution Mower" sign on the rear of each mower. In addition, the Contractor shall display his company name on each tractor.

The Contractor shall furnish all equipment in good operating condition and operated by properly trained and qualified personnel. There will be **no payment for mobilization** of labor and equipment, as it will be **considered incidental** to the bid items of this contract. The Contractor shall be responsible for all costs or charges incurred in the operation and maintenance of the equipment during the performance of this contract.

Mulching (Not In Maintained Yards/Properties)

The Contractor shall mulch all cuttings to a size not greater than 1 inch wide and 4 inches long. Mulching can be achieved by the use of the long arm mower, chipper or other method as approved by the Engineer.

All equipment shall be equipped with shields/guards which precludes foreign objects from being thrown out from the cutting unit. The Contractor shall be responsible for all costs or charges incurred in the operation and maintenance of the equipment during the term of the contract including, but not limited to; fuel, oil, equipment repairs, etc. Mulching shall be considered incidental to the long arm mowing operation and the Contractor will be compensated for any equipment operation and incidentals at the Equipment Operating Rate defined elsewhere in this contract.

Debris Pickup (Within Limits of Maintained Yards/Properties)

The Contractor will be required to pick up and remove all cuttings that are within the limits of a maintained yard/property. Pickup/Removal shall be considered incidental to the long arm mowing operation and the Contractor will be compensated for all pickup/removal at the Equipment Operating Rate defined elsewhere in this contract.

Traffic Control and Work Zone Safety:

All personnel when working in traffic areas or areas in close proximity to traffic shall wear an approved safety vest, or shirt or jacket which meets the color requirements of the Manual of Uniform Traffic Control Devices (MUTCD). All work vehicles shall be equipped with an outside blinking amber light visible from all directions.

The work zone sign shall be a portable sign 48" x 48" and stand specifically designed for one another, and should be 5 feet off the ground (refer to NCDOT 2012 Roadway Standard Drawing 1110.01) Signs shall be composite, aluminum or retro-reflective roll-up (Non-reflective Mesh Signs will not be accepted). It should be mounted 3' minimum from travel lane of the right shoulder or in the median in advance of the long arm mowing operation and should be relocated regularly to maintain a work zone of 2-mile maximum length. Care should be taken that this sign is displayed only while long arm mowing work is underway.

Long arm mowing operations normally progress slower than 3 mph with frequent stops. Work shall be performed a minimum of four (4) feet from the travel lane.

Work less than four (4) feet from the travel lane on roads with two-way traffic shall require “temporary Lane Closures” (refer to NCDOT 2012 Roadway Standard F=Drawings 1101.02). The Contractor shall furnish, install and maintain advance warning work zone signs and required lane closure signing and devices. Traffic movements through lane closures shall be controlled by flaggers stationed at each end of the work zone. In situations where sight distance is limited, the Contractor shall provide additional means of controlling traffic, including, but not limited to, two-way radios, pilot vehicles or additional flaggers. All flaggers shall be **Certified Work Zone Flaggers** and shall be furnished with proper safety devices and equipment, including, but not limited to, safety vests, hats, stop/slow paddles and any other incidentals necessary to complete the work.

Work within 4 to 40 feet of the travel lane of divided multi-lane highways, shall require appropriate advance warning signs.

“Deadheading” of equipment shall not be permitted. Equipment requiring to be relocated from one project site to another shall be transported by trailer.

In accordance with NCDOT 2012 Standard Specifications 107-21, the Contractor shall comply with all applicable Federal, State and local laws, ordinances and regulations governing safety, health and sanitation and shall provide all safeguards, safety devices, protective equipment and shall take any other needed actions, on his own responsibility that are reasonably necessary to protect the life and health of employees of the job and the safety of the public, and to protect property on connection with the performance of the work covered by the contract.

Failure to comply with any of the requirements for safety and traffic control of this contract shall result in suspension of work as provided in NCDOT 2012 *Standard Specifications* Section 108-7.

Measurement and Payment

Long Arm Mowing shall be measured and paid as the actual number of shoulder miles acceptably mowed. Such price and payment will be full compensation for all work including, but not limited to, furnishing labor and equipment to mow. No separate payment will be made for traffic control, mulching, debris removal or disposal.

A standard pay record book will be maintained by NCDOT personnel for all hours worked by the Contractor. The Contractor and NCDOT personnel will be required to initial each and every entry daily. The Contractors duly authorized supervisor may sign on behalf of all operators and the contractor.

Payment will be made under:

Pay Item

Two (2) Fully Operated Long Arm Mowing Tractors with Traffic Control

Pay Unit

Shoulder Mile

MOWING LIMITS

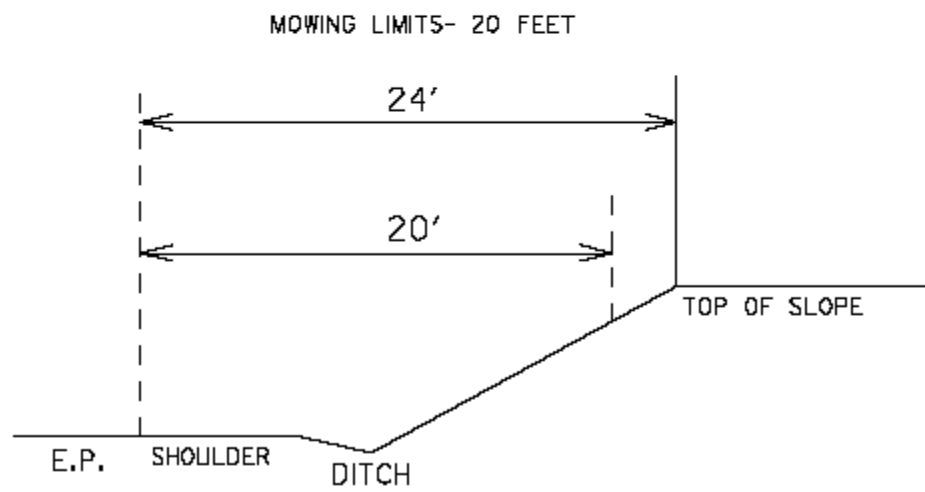
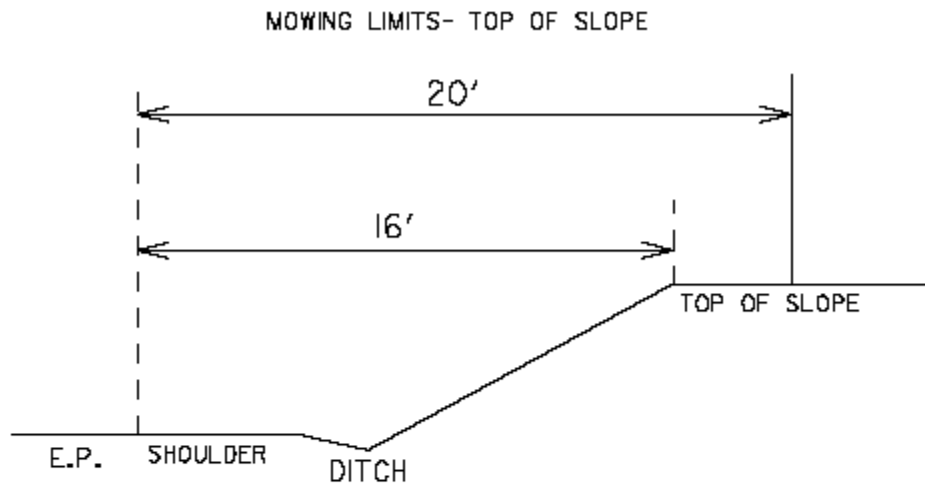

MOWING LIMITS- TOE OF SLOPE

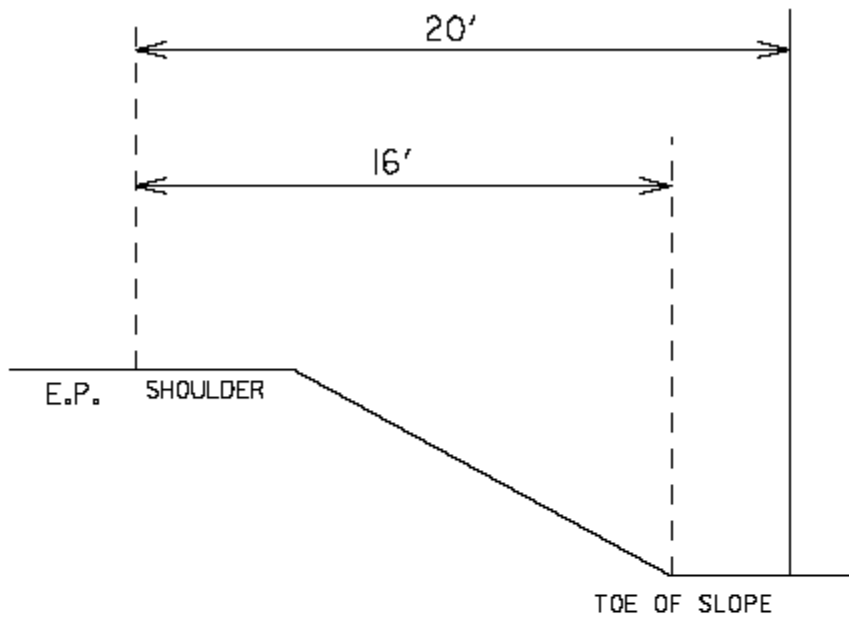

MOWING LIMITS- 20 FEET

